

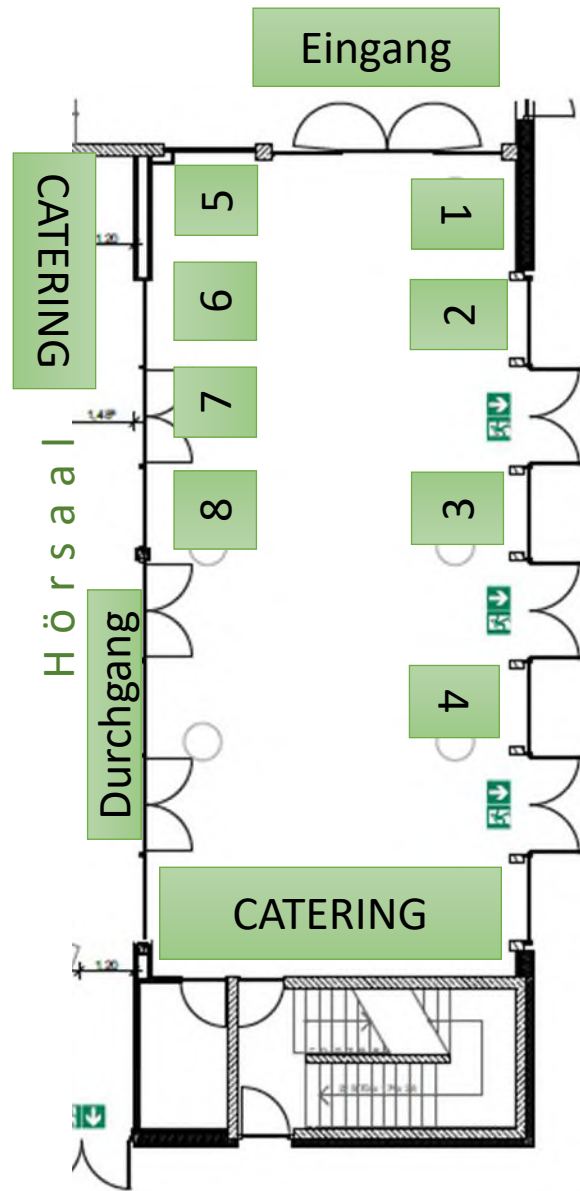





3. Augsburger Neurodermitis-Symposium

Breaking Barriers: Unterschiedliche Perspektiven auf die schützenden und verletzlichen Aspekte der Haut

Internationales Symposium im Westhouse Augsburg, 25.-26. Februar 2025

Industrierausstellung



Firma	Strom	Standnummer
		1
GALDERMA <small>EST. 1981</small>		2
		3
Eucerin [®]		4
		5
sanofi REGENERON [®]		6
		7
		8

Saal Westhouse:

<https://cloud.dimension3.de/show/?m=tQguShMD3iQ&mpu=154&mpv=saal>

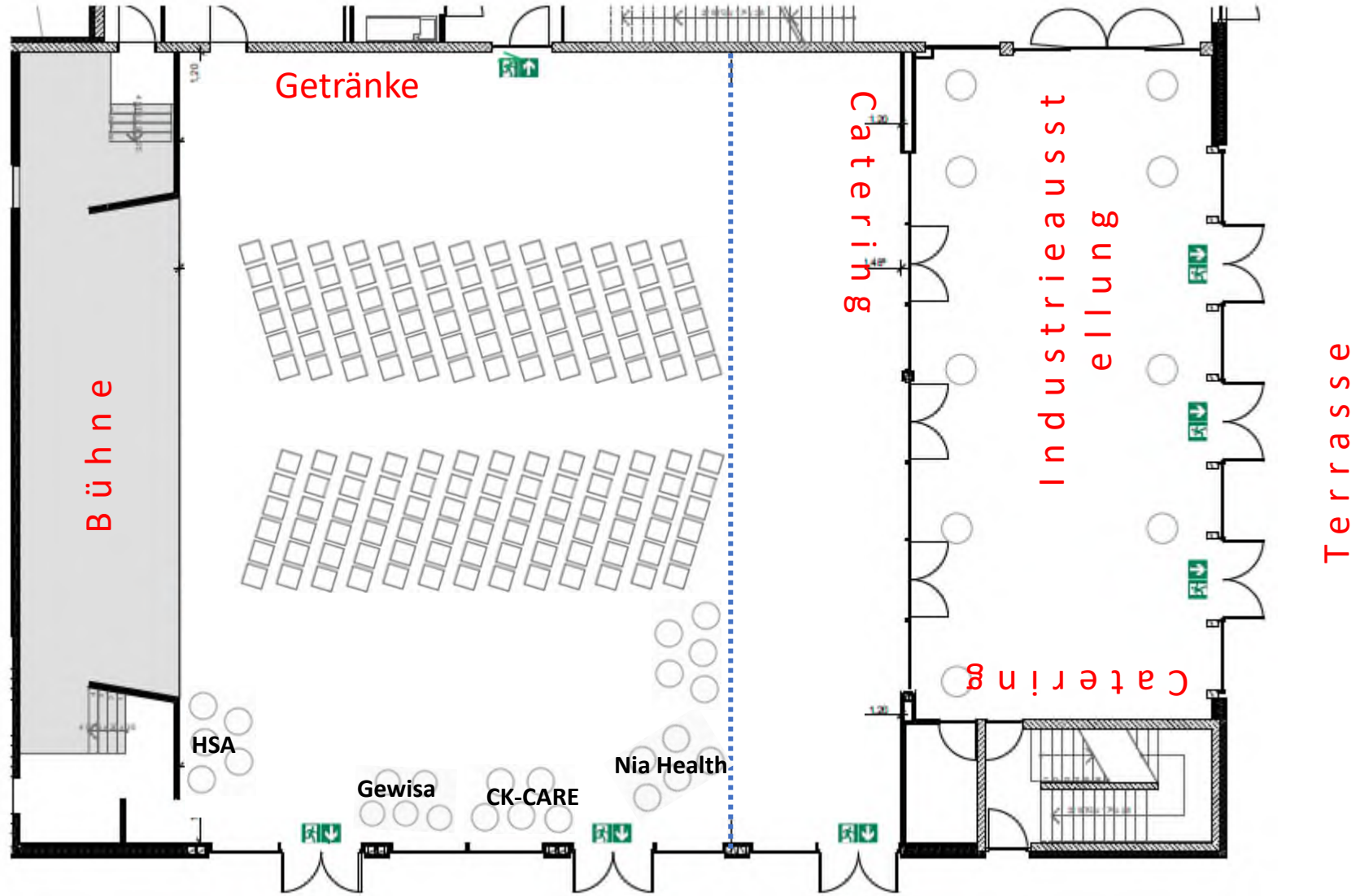

A BIG Thank you to all our sponsors for their support!

Platinum Sponsors



by Kühne Foundation

CK-CARE AG – 10.000 CHF



Andreas Schmid
Group

Andreas Schmid Logistik AG – 5.000 Euro

aumüller ■

Aumüller Aumatic GmbH – 7.000 Euro



Landbäckerei IHLE GmbH & Co. KG – 5.000 Euro

Exhibitors/Industrie Sponsors



almirall

Almirall Hermal GmbH – 2000 Euro

Eucerin[®]

Beiersdorf AG - 3.500 Euro

GALDERMA

EST. 1981

Galderma Laboratorium GmbH – 3.500 Euro

LA ROCHE POSAY
LABORATOIRE DERMATOLOGIQUE
L'Oréal Deutschland GmbH – 3.500 Euro



LEO Pharma GmbH – 3.500 Euro

Lilly

Lilly Deutschland GmbH – 4.700 Euro



Nia Health GmbH – 1.700 Euro

 **NOVARTIS**

Novartis Pharma GmbH – 3.500 Euro

sanofi | **REGENERON**[®]

Sanofi-Aventis Deutschland GmbH – 3.500 Euro